

SRI986

Electro-Pneumatic Positioner

Rev 2.0

Accessories for the positioner (Fig. 1)

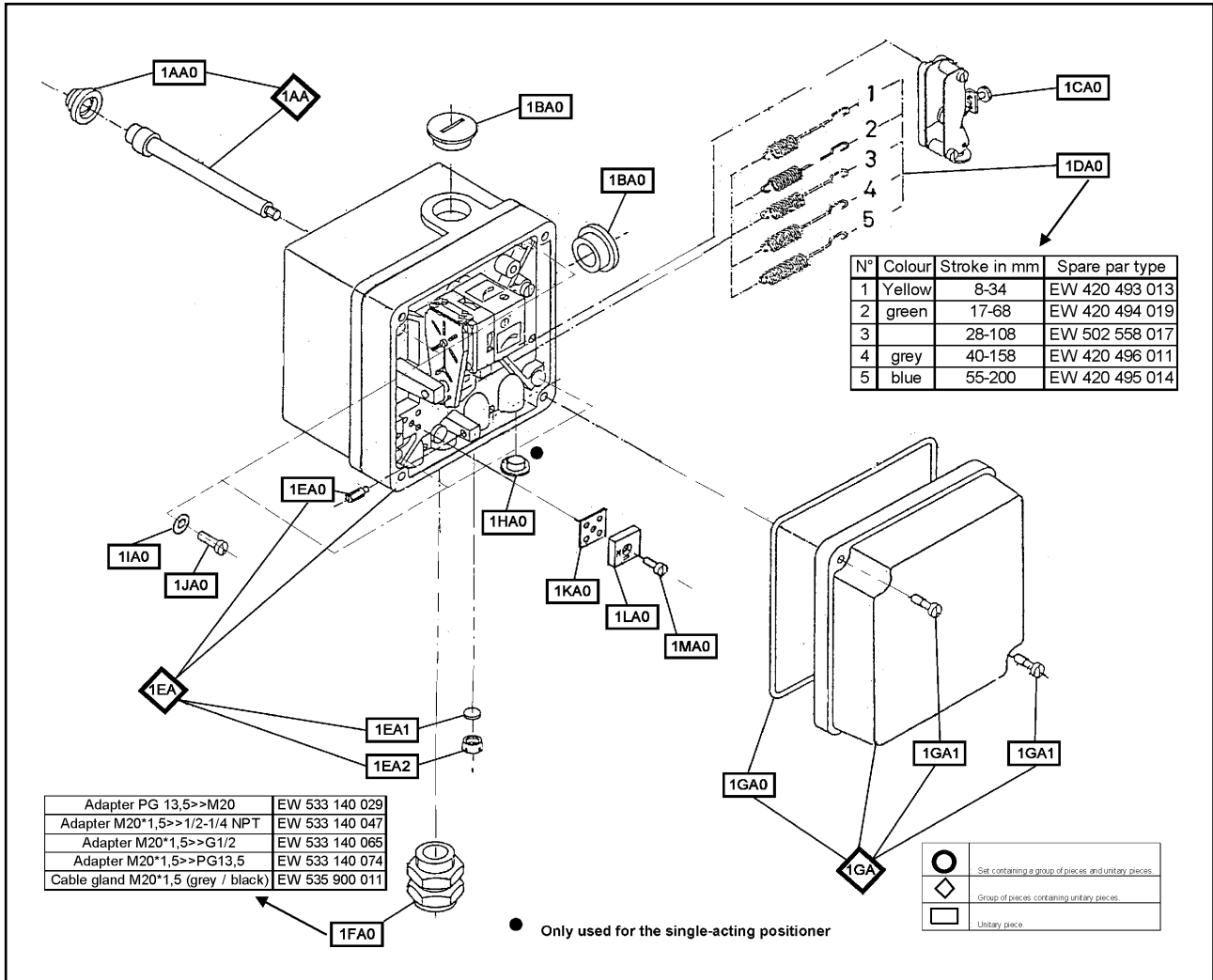

Accessories for the positioner (following) (Fig. 2)

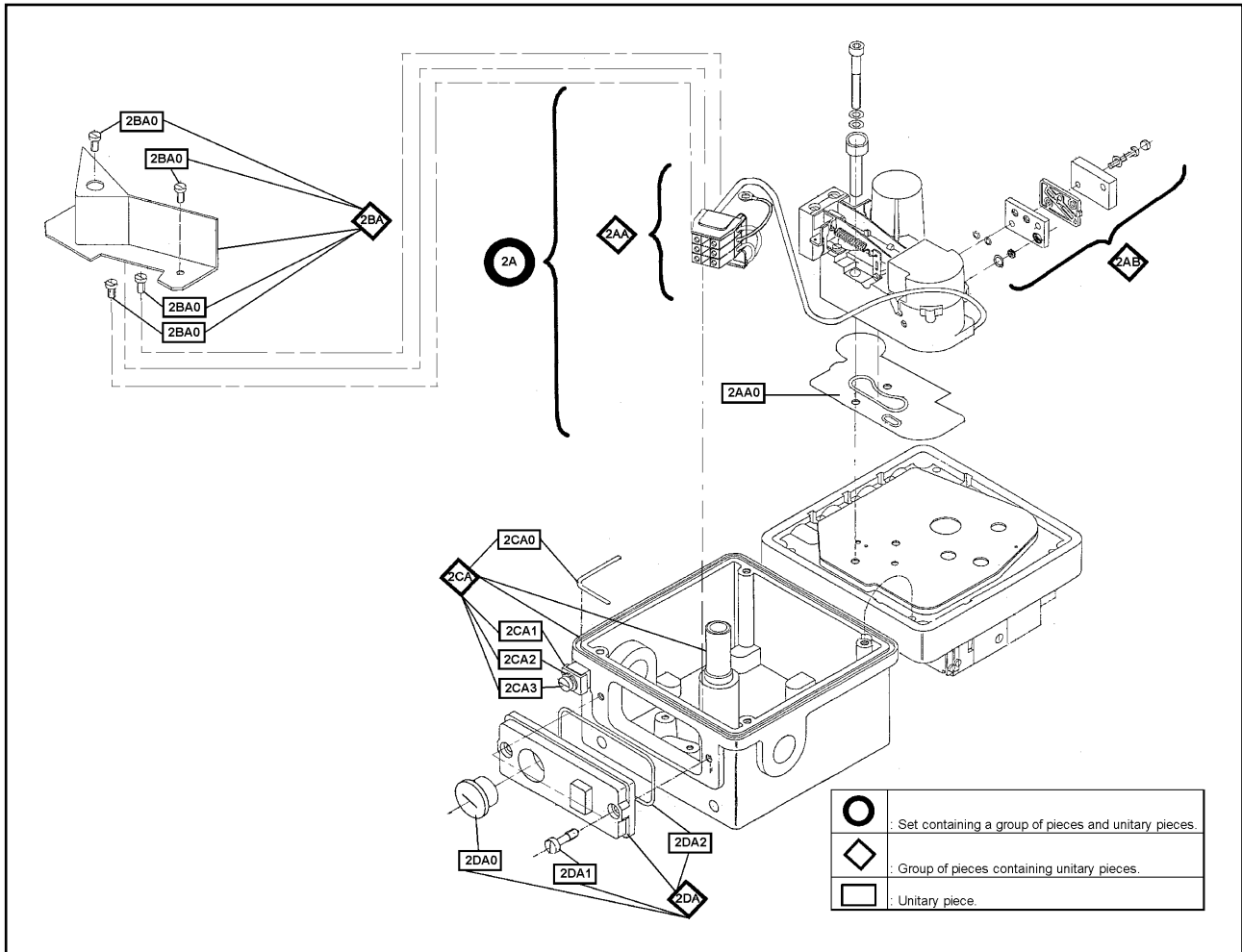

Pneumatic Part (single-acting) (Fig. 3)

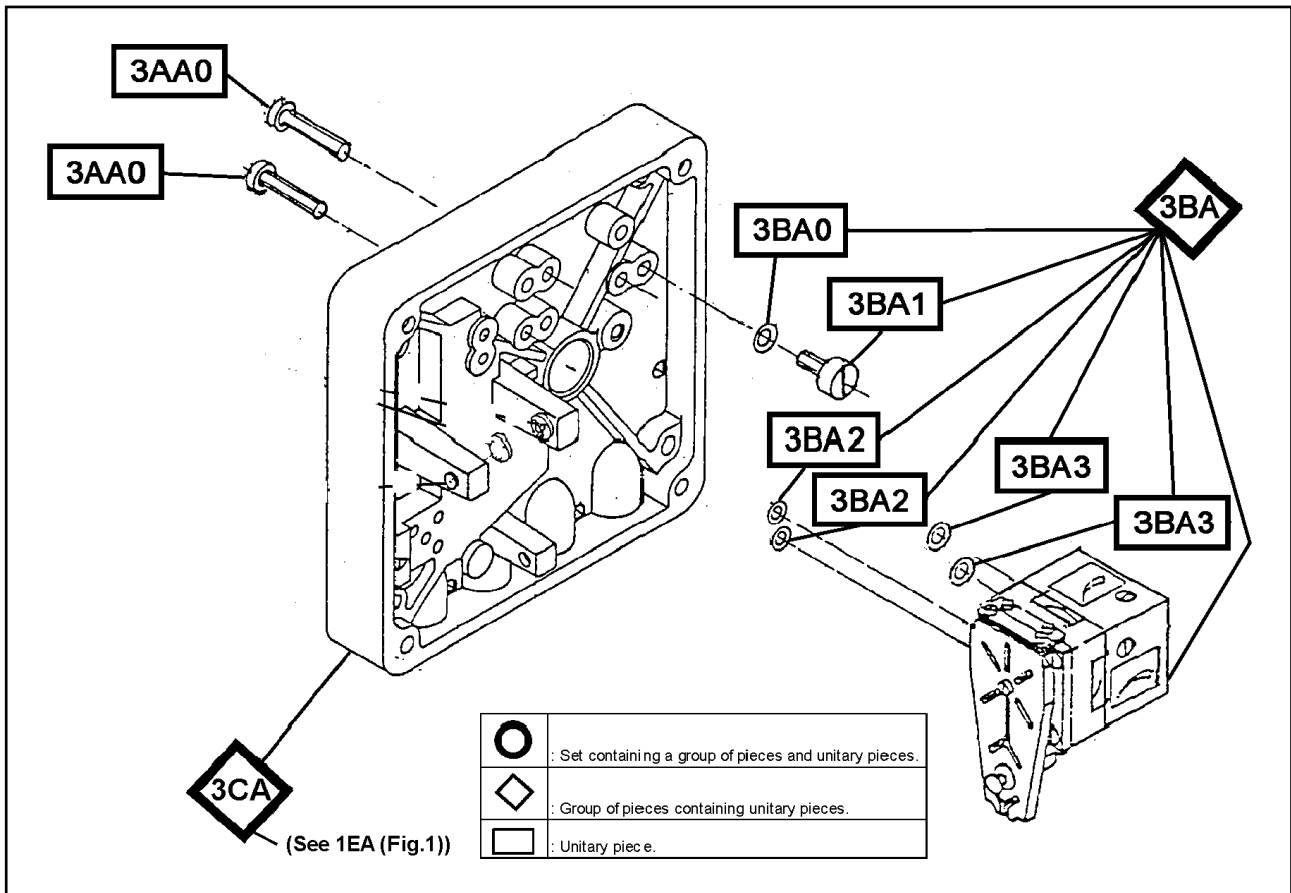

Pneumatic Part (double-acting) (Fig. 4)

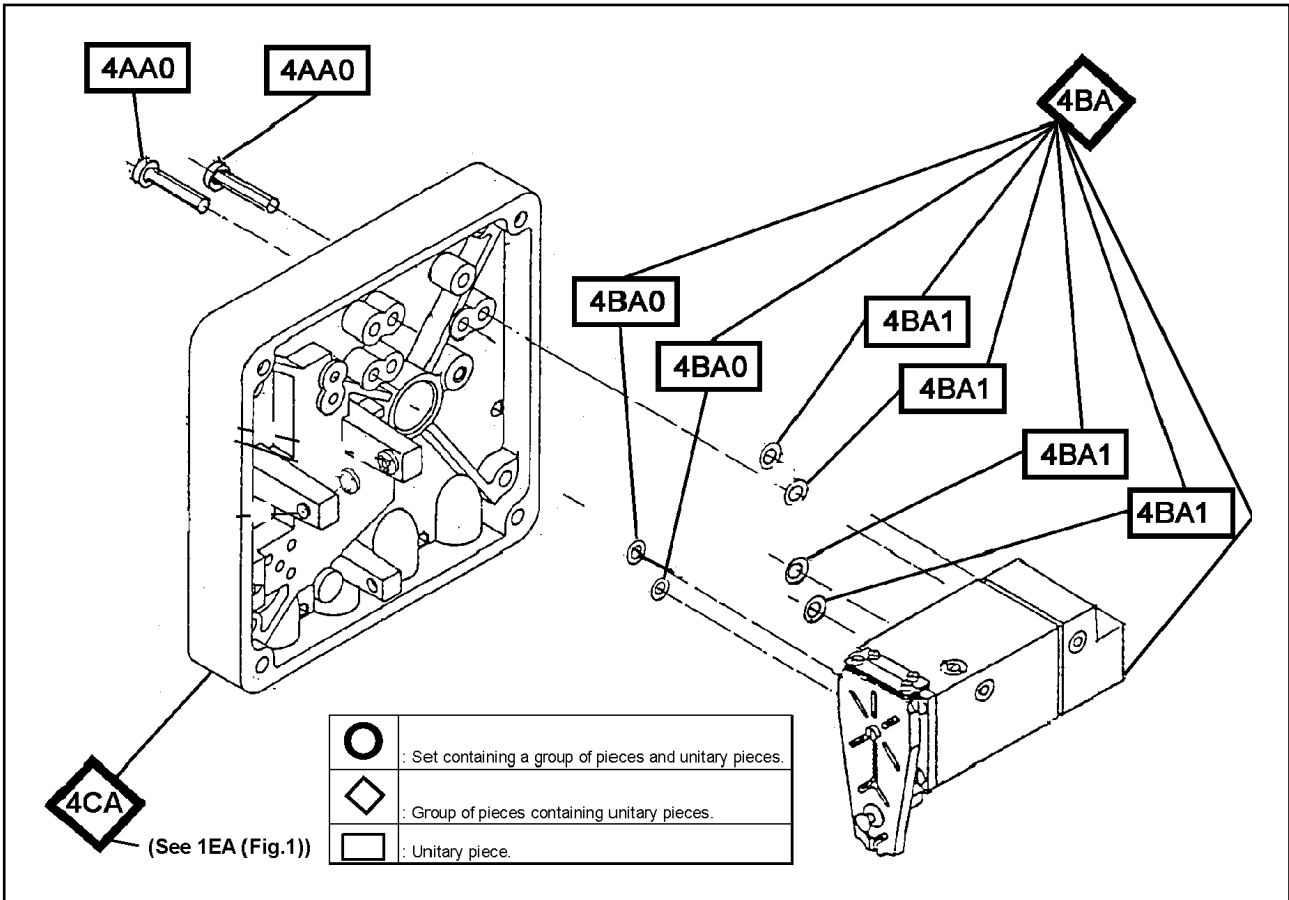

Amplifier single-acting (Fig. 5)

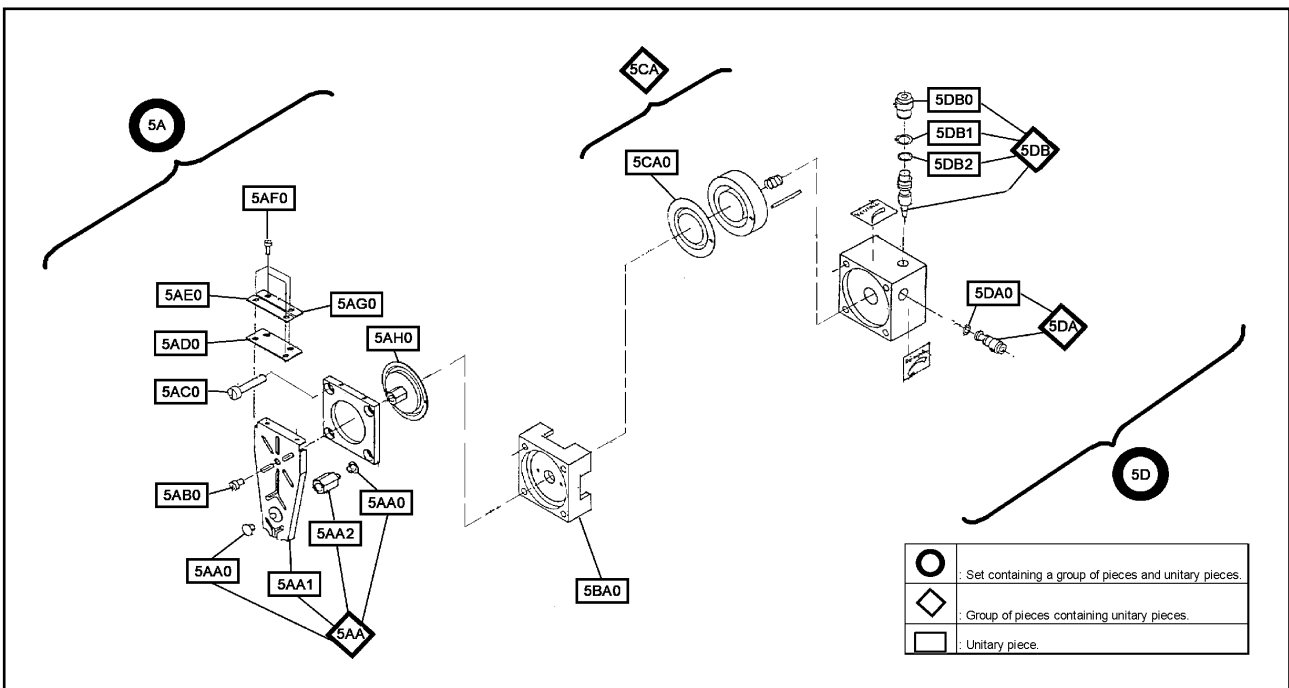

Amplifier double-acting (Fig. 6)

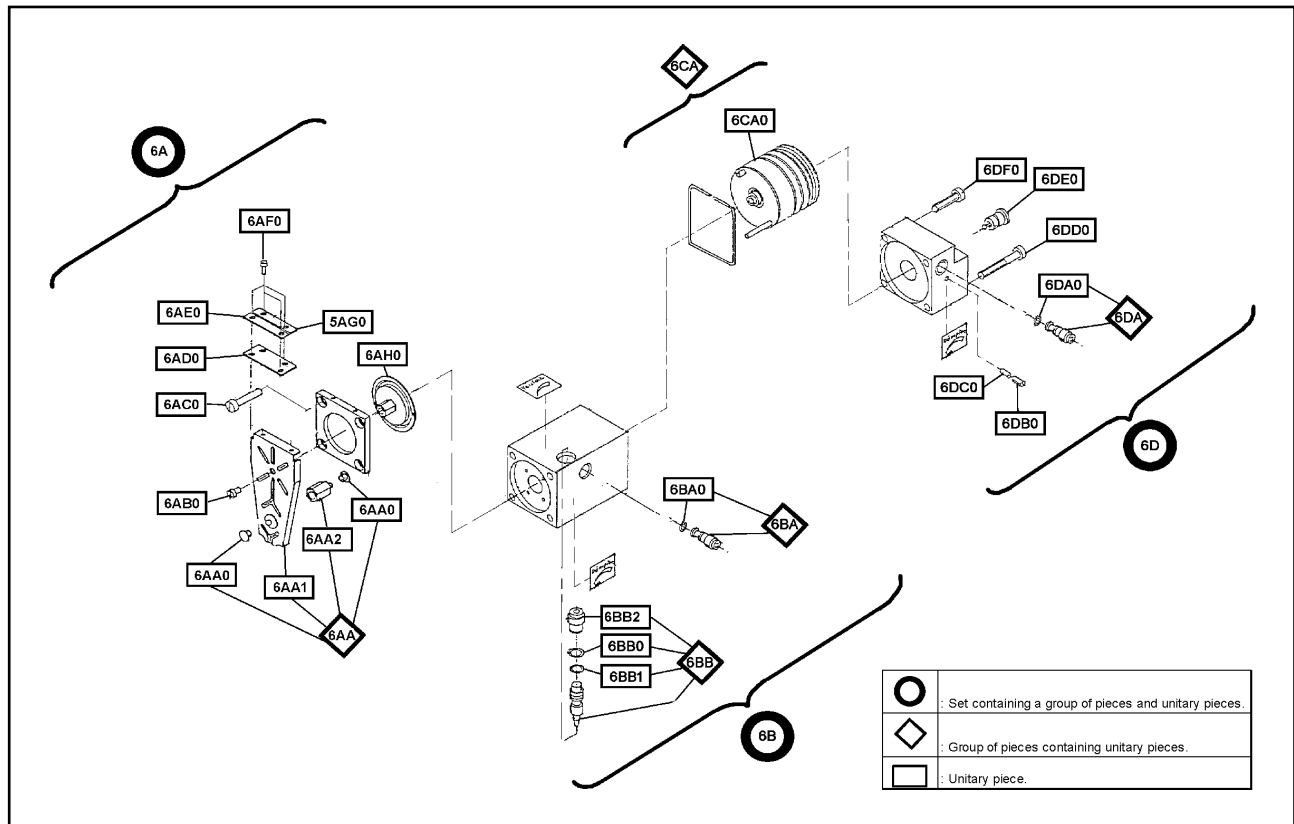

Limit switch assembly (Fig. 7)

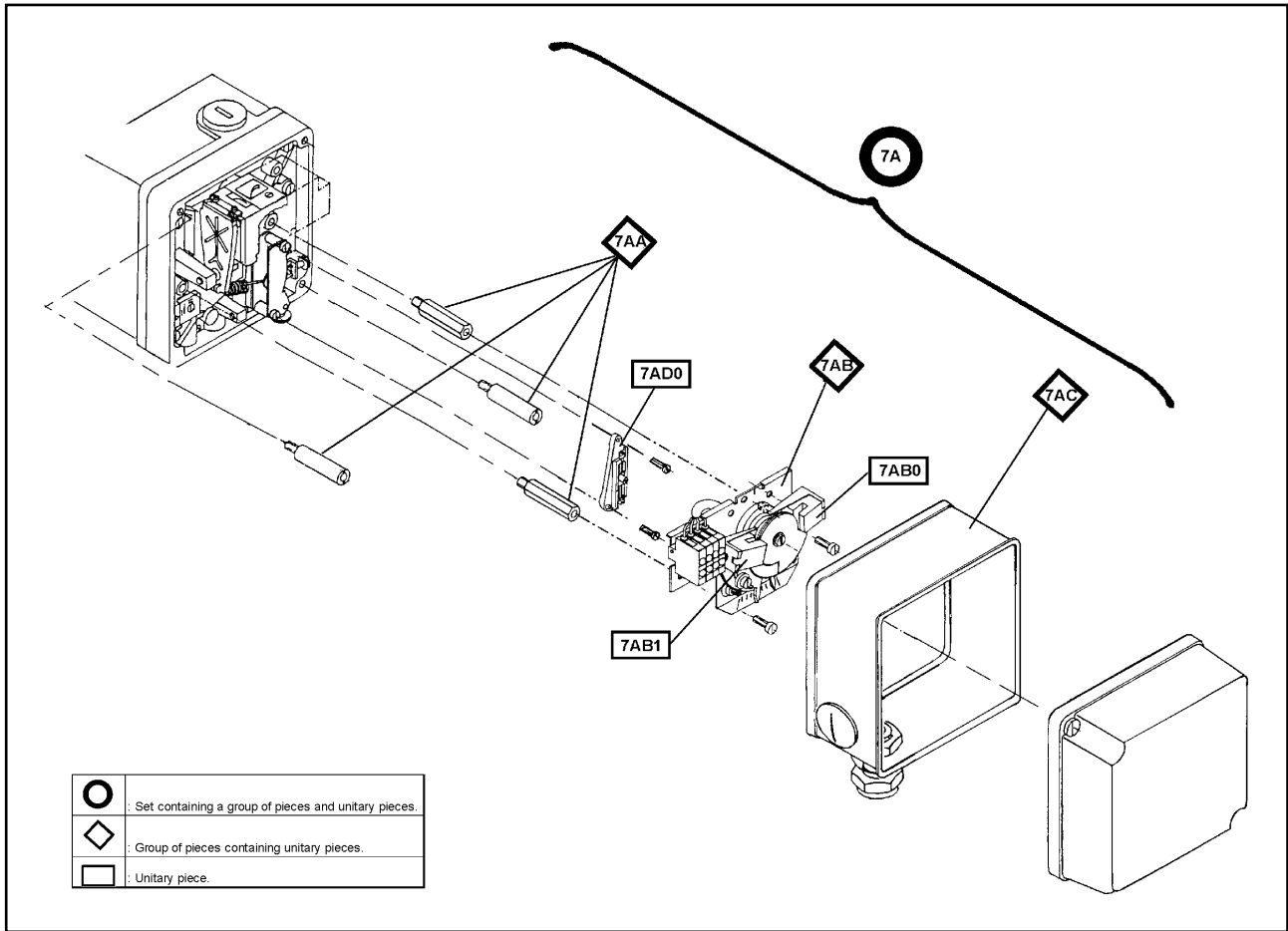

Position Transmitter (Fig. 8)

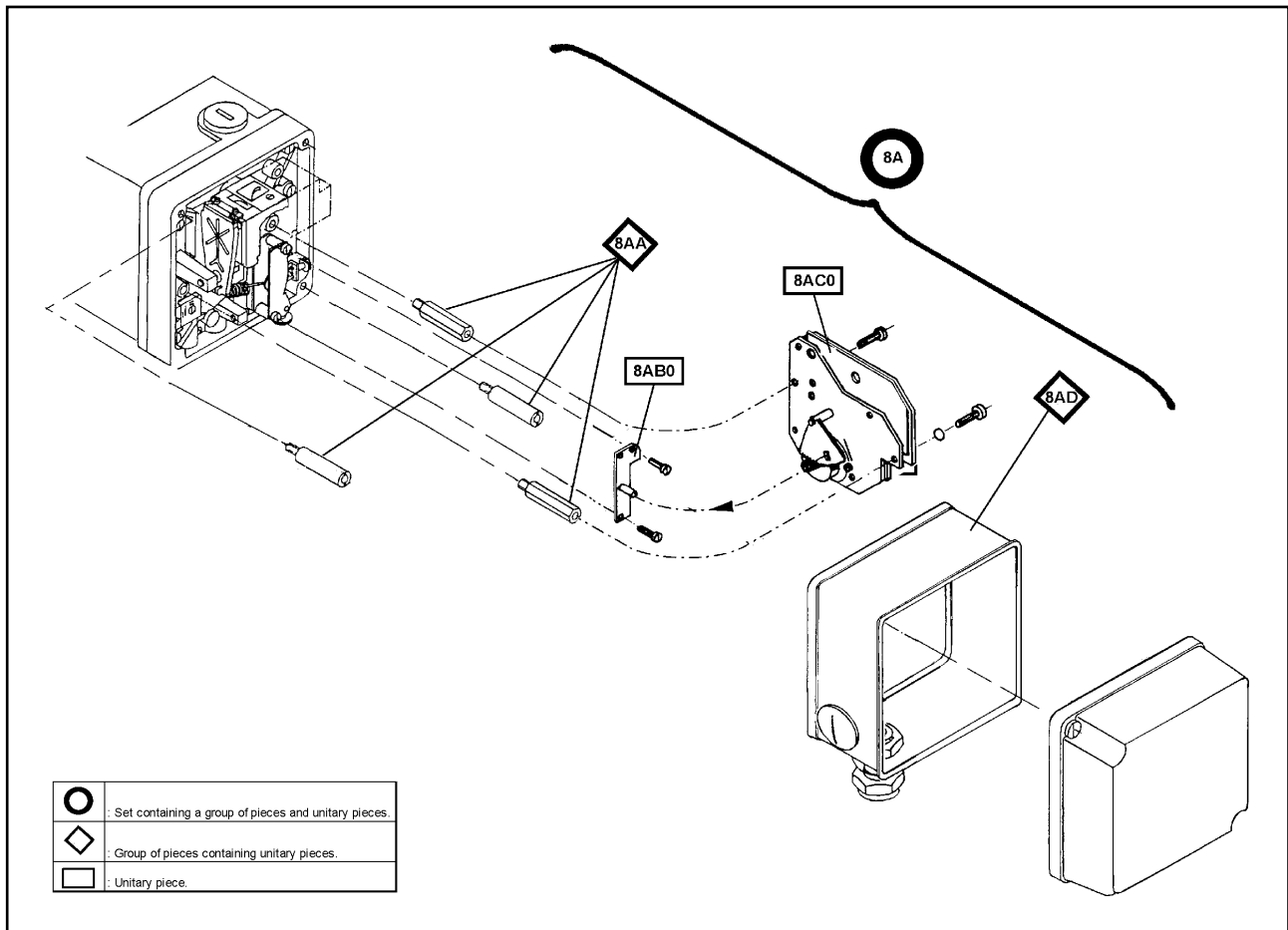

Pos.	Number	Cnt.	Description
1AA			Shaft
	EW 411 406 296	1	Shaft
1AA0			Plug (in Service Kit single / double-acting EW 411 406 082)
	EW 515 885 012	1	Plug (in Service Kit single / double-acting EW 411 406 082)
1BA0			Plug screw
	EW 523 870 033	1	
1CA0			Adjusting Device
	EW 411 406 091	1	Adjusting device
1EA			Air duct plate
	EW 411 406 064	1	Air duct plate
1EA0			Threaded pin M4*10
	EW 507 928 031	1	Threaded pin M4*10
1EA1			Filter (in Service Kit single / double-acting EW 411 406 082)
	EW 515 807 014	1	Filter (in Service Kit single / double-acting EW 411 406 082)

Pos.	Number	Cnt.	Description
1EA2			Nut (in Service Kit single / double-acting EW 411 406 082)
	EW 510 661 014	1	Nut (in Service Kit single / double-acting EW 411 406 082)
1GA			Cover SRI986 (standard)
	EW 411 406 055	1	Cover SRI986 (standard)
1GA0			O-ring (NBR) 120*2,5 (in Service Kit single / double-acting EW 411 406 082)
	EW 502 081 826	1	O-ring (NBR) 120*2,5 (in Service Kit single / double-acting EW 411 406 082)
1GA1			Screw CHC M4*7 (2 screws in Service Kit single / double-acting EW 411 406 082)
	EW 507 839 021	1	Screw CHC M4*7 (2 screws in Service Kit single / double-acting EW 411 406 082)
1HA0			Plug
	EW 508 103 072	1	Plug standard
	EW 508 085 018	1	Plug IP65
1IA0			Washer
	EW 555 563 535	1	Washer
1JA0			Screw CHC M4*22
	EW 507 882 077	1	Screw CHC M4*22
1KA0			Gasket (in Service Kit single / double-acting EW 411 406 082)
	EW 502 170 018	1	Gasket (in Service Kit single / double-acting EW 411 406 082)
1LA0			Plate (in Service Kit single / double-acting EW 411 406 082)
	EW 505 152 015	1	Plate (in Service Kit single / double-acting EW 411 406 082)
1MA0			Screw CHC M3*8 (in Service Kit single / double-acting EW 411 406 082)
	EW 507 882 449	1	Screw CHC M3*8 (in Service Kit single / double-acting EW 411 406 082)
			Kit "IP 65" (not illustrated)
	EW 411 406 301	1	Kit "IP 65" (not illustrated)
2A			IP modul (ATEX)
	EW 411 406 454	1	IP modul (ATEX)
2AA0			O-ring (NBR) incl. Service Kit single / double-acting
	EW 556 541 017	1	O-ring (NBR) incl. Service Kit single / double-acting
2AA			Terminals (in Service Kit single / double-acting EW 411 406 082)
	EW 411 406 082	1	Service Kit single / double-acting
2AB			System venturi incl. Service Kit single / double-acting
	EW 411 406 082	1	Service Kit single / double-acting
2BA			Plastic cache
	EW 411 406 321	1	Plastic cache
2BA0			Screw CS M3*6
	EW 507 882 431	1	Screw CS M3*6
2CA			Housing of the SRI 986
	EW 411 406 375	1	Housing of the SRI 986
2CA0			O-ring (NBR) 128*2 incl. Service Kit single / double-acting
	EW 411 406 082	1	Service Kit single / double-acting
2CA1			U-bolt
	EW 500 146 048	1	U-bolt
2CA2			Washer
	EW 555 491 402	1	Washer
2CA3			Screw CHC M5*12
	EW 507 882 848	1	Screw CHC M5*12

Pos.	Number	Cnt.	Description
2DA			Cover
	EW 411 406 287	1	Cover
2DA0			Plug screw
	EW 523 870 033	1	
2DA1			Screw CHC M4*8 (2 screws in Service Kit single / double-acting EW 411 406 082)
	EW 507 839 041	1	Screw CHC M4*8 (2 screws in Service Kit single / double-acting EW 411 406 082)
2DA2			O-ring (NBR) 50*2 (in Service Kit single / double-acting EW 411 406 082)
	EW 502 081 817	1	O-ring (NBR) 50*2 (in Service Kit single / double-acting EW 411 406 082)
3AA0			Screw CHC M3*20
	EW 507 882 012	1	Screw CHC M3*20
3BA			Amplifier single-acting
	EW 411 406 019	1	Amplifier single-acting
	EW 411 406 037	1	Amplifier single-acting free of nonferrous metals
3BA0			Washer (2 washers in Service Kit single / double-acting EW 411 406 082)
	EW 502 076 102	1	Washer (2 washers in Service Kit single / double-acting EW 411 406 082)
3BA1			Screw CHC M4*8 (in Service Kit single / double-acting EW 411 406 082)
	EW 507 882 769	1	Screw CHC M4*8 (in Service Kit single / double-acting EW 411 406 082)
3BA2			O-ring (NBR) 2,5*1,2 (4 o-rings in Service Kit single / double-acting EW 411 406 082)
	EW 502 081 055	1	O-ring (NBR) 2,5*1,2 (4 o-rings in Service Kit single / double-acting EW 411 406 082)
3BA3			O-ring (NBR) 4*1,5 (4 o-rings in Service Kit single / double-acting EW 411 406 082)
	EW 502 081 107	1	O-ring (NBR) 4*1,5 (4 o-rings in Service Kit single / double-acting EW 411 406 082)
4AA0			Screw CHC M3*20
	EW 507 882 012	1	Screw CHC M3*20
4BA			Amplifier double-acting
	EW 411 406 312	1	Amplifier double-acting
4BA0			O-ring (NBR) 2,5*1,2 (4 o-rings in Service Kit single / double-acting EW 411 406 082)
	EW 502 081 055	1	O-ring (NBR) 2,5*1,2 (4 o-rings in Service Kit single / double-acting EW 411 406 082)
4BA1			O-ring (NBR) 4*1,5 (4 o-rings in Service Kit single / double-acting EW 411 406 082)
	EW 502 081 107	1	O-ring (NBR) 4*1,5 (4 o-rings in Service Kit single / double-acting EW 411 406 082)
5A			Kit feeler level (single / double)
	EW 411 406 107	1	Kit feeler level (single / double)
5AA			Feeler lever
	EW 411 406 418	1	Feeler lever
5AA0			Flapper platte (2 flappers platte in Service Kit single / double-acting EW 411 406 082)
	EW 505 282 014	1	Flapper platte (2 flappers platte in Service Kit single / double-acting EW 411 406 082)
5AA1			Lever
	EW 401 170 014	1	Lever

Pos.	Number	Cnt.	Description
5AA2			Hexagonal nut
	EW 401 849 029	1	Hexagonal nut
5AB0			Screw CS M2,5*4
	EW 508 865 498	1	Screw CS M2,5*4
5AC0			Screw CS M3*5
	EW 507 882 129	1	Screw CS M3*16
5AD0			Leaf spring (in Service Kit single / double-acting EW 411 406 082)
	EW 502 311 018	1	Leaf spring (in Service Kit single / double-acting EW 411 406 082)
5AE0			Ledge
	EW 504 149 024	1	Ledge
5AF0			Screw CS M2*4 (4 screws platte in Service Kit single / double-acting EW 411 406 082)
	EW 507 829 116	1	Screw CS M2*4 (4 screws platte in Service Kit single / double-acting EW 411 406 082)
5AG0			Ledge
	EW 504 149 015	1	Ledge
5AH0			Diaphragm group
	EW 411 406 125	1	Diaphragm group
	EW 411 406 125	1	Diaphragm group
5BA0			Housing
	EW 401 037 038	1	Housing
5CA			Diaphragm group for amplifier single-acting
	EW 411 406 116	1	Diaphragm group for amplifier single-acting
	EW 411 406 393	1	Diaphragm group for amplifier single-acting aluminium
5CA0			Diaphragm
	EW 504 233 026	1	Diaphragm
5D			Behind housing for amplifier single-acting
	EW 411 406 348	1	Behind housing for amplifier single-acting
	EW 411 406 357	1	Behind housing for amplifier single-acting aluminium
5DA			Trotting screw with o-ring
	EW 411 406 436	1	Trotting screw with o-ring
5DA0			O-ring (NBR) 2,5*1,2 (4 o-rings in Service Kit single / double-acting EW 411 406 082)
	EW 502 081 055	1	O-ring (NBR) 2,5*1,2 (4 o-rings in Service Kit single / double-acting EW 411 406 082)
5DB			Trotting screw with o-rings
	EW 411 406 445	1	Trotting screw with o-rings
5DB0			Trotting screw incl. Service Kit single / double-acting
	EW 411 406 082	1	Service Kit single / double-acting
5DB1			O-ring (NBR) 5*1 (2 o-rings in Service Kit single / double-acting EW 411 406 082)
	EW 502 124 252	1	O-ring (NBR) 5*1 (2 o-rings in Service Kit single / double-acting EW 411 406 082)
5DB2			O-ring (NBR) 3*1 (3 o-rings in Service Kit single / double-acting EW 411 406 082)
	EW 502 081 116	1	O-ring (NBR) 3*1 (3 o-rings in Service Kit single / double-acting EW 411 406 082)
6A			Kit feeler level (single / double)
	EW 411 406 107	1	Kit feeler level (single / double)
6AA			Feeler lever
	EW 411 406 418	1	Feeler lever
6AA0			Flapper platte (2 flappers platte in Service Kit single / double-acting EW 411 406 082)
	EW 505 282 014	1	Flapper platte (2 flappers platte in Service Kit single / double-acting EW 411 406 082)

Pos.	Number	Cnt.	Description
6AA1			Lever
	EW 401 170 014	1	Lever
6AA2			Hexagonal nut
	EW 401 849 029	1	Hexagonal nut
6AB0			Screw CS M2,5*4
	EW 508 865 498	1	Screw CS M2,5*4
6AC0			Screw CS M3*16
	EW 507 882 129	1	Screw CS M3*16
6AD0			Leaf spring (in Service Kit single / double-acting EW 411 406 082)
	EW 502 311 018	1	Leaf spring (in Service Kit single / double-acting EW 411 406 082)
6AE0			Ledge
	EW 504 149 024	1	Ledge
6AF0			Screw CS M2*4 (4 screws platte in Service Kit single / double-acting EW 411 406 082)
	EW 507 829 116	1	Screw CS M2*4 (4 screws platte in Service Kit single / double-acting EW 411 406 082)
6AG0			Ledge
	EW 504 149 015	1	Ledge
6AH0			Diaphragm group
	EW 411 406 125	1	Diaphragm group
6B			Front housing of the double-acting
	EW 411 406 366	1	Front housing of the double-acting
6BA			Trotting screw with o-ring
	EW 411 406 436	1	Trotting screw with o-ring
6BA0			O-ring (NBR) 2,5*1,2 (4 o-rings in Service Kit single / double-acting EW 411 406 082)
	EW 502 081 055	1	O-ring (NBR) 2,5*1,2 (4 o-rings in Service Kit single / double-acting EW 411 406 082)
6BB			Trotting screw with o-rings
	EW 411 406 445	1	Trotting screw with o-rings
6BB0			O-ring (NBR) 5*1 (2 o-rings in Service Kit single / double-acting EW 411 406 082)
	EW 502 124 252	1	O-ring (NBR) 5*1 (2 o-rings in Service Kit single / double-acting EW 411 406 082)
6BB1			O-ring (NBR) 3*1 (3 o-rings in Service Kit single / double-acting EW 411 406 082)
	EW 502 081 116	1	O-ring (NBR) 3*1 (3 o-rings in Service Kit single / double-acting EW 411 406 082)
6BB2			Trotting screw incl. Service Kit single / double-acting
	EW 411 406 082	1	Service Kit single / double-acting
6CA			Diaphragm group for amplifier double-acting
	EW 411 406 251	1	Diaphragm group for amplifier double-acting
6CA0			Diaphragm
	EW 415 980 023	1	Diaphragm
6D			Behind housing for amplifier double-acting
	EW 411 406 339	1	Behind housing for amplifier double-acting
6DA			Trotting screw with o-ring
	EW 411 406 436	1	Trotting screw with o-ring
6DA0			O-ring (NBR) 2,5*1,2 (4 o-rings in Service Kit single / double-acting EW 411 406 082)
	EW 502 081 055	1	O-ring (NBR) 2,5*1,2 (4 o-rings in Service Kit single / double-acting EW 411 406 082)

Pos.	Number	Cnt.	Description
6DB0			Threaded pin M3*6
	EW 527 334 011	1	Threaded pin M3*6
6DC0			Pin
	EW 522 629 015	1	Pin
6DD0			Screw CS M3*25
	EW 507 882 742	1	Screw CS M3*25
6DE0			Sleeve
	EW 415 979 038	1	Sleeve
6DF0			Screw CS M3*16
	EW 507 882 129	1	Screw CS M3*16
7A			Kit limit switch assembly (standard)
	EW 419 510 343	1	Kit limit switch assembly standard version
	EW 419 510 361	1	Kit limit switch assembly security version
	EW 419 510 307	1	Kit limit switch assembly Three-Wire Technique
	EW 420 421 026	1	Kit limit switch assembly with two Micro Switches
7AA			Pilar for limit switch assembly
	EW 411 406 222	1	Pilar for limit switch assembly
7AB			Limit switch assembly
	EW 419 495 041	1	Limit switch assembly standard version
	EW 419 495 059	1	Limit switch assembly security version
	EW 419 495 032	1	Limit switch assembly Three-Wire Technique
	EW 420 422 012	1	Limit switch assembly with two Micro Switches
7AB0			Contact
	EW 414 920 027	1	Contact standard version
	EW 414 638 021	1	Contact security version
	EW 530 115 012	1	Contact Three-Wire Technique
	EW 420 420 022	1	Contact Micro Switch
7AB1			Contact
	EW 414 920 027	1	Contact standard version
	EW 414 638 021	1	Contact security version
	EW 530 115 012	1	Contact Three-Wire Technique
	EW 420 420 011	1	Contact Micro Switch
7AC			Cover
	EW 411 406 427	1	Cover
7AD0			Kit adjusting
	EW 419 340 019	1	Kit adjusting
8A			Position Transmitter Kit
	EW 420 661 106	1	Position Transmitter Kit
8AA			Pilar for limit Position Transmitter
	EW 411 406 242	1	Pilar for limit Position Transmitter for the double acting
8AB0			Adjusting plate
	EW 420 662 013	1	Adjusting plate
8AC0			Position Transmitter
	EW 420 664 032	1	Position Transmitter
8AD			Cover
	EW 411 406 427	1	Cover
8BA0			Adjustscrew (not illustrated)
	EW 528 037 016	1	

Important notices:

For spare parts supplies for devices with certification resp. for supply of spare parts with certification we only warrant that the supplied spare part in its delivery condition is suitable for the certification as indicated by purchaser.

Validity of a certification generally becomes effective after orderly assembly to the complete device. Herefore, we do not assume any guarantee.

For the repair and change of explosionproof devices, the national regulations have to be observed.

Indicate complete model code of original device as far as possible when ordering spare parts. Only valid model code combinations are allowed.

Subject to alterations - reprinting, copying and translation prohibited. Products and publications are normally quoted without reference to existing patents, registered utility models or trademarks. The lack of any such reference does not justify the assumption that a product or symbol is free.

Foxboro Eckardt GmbH
Postfach 50 03 47
D-70333 Stuttgart
Tel. # 49 (0)711 502-0
Fax # 49 (0)711 502-597

